



DISTRIBUTED SCADA TECHNOLOGY

Redefining SCADA for Comprehensive Distributed Utilities Solutions

By James M. DiNanno

SEMAPHORE
a CSE-Global Group Company

Introduction

The burden being placed on municipal utilities continues to increase. Customers demand quick problem identification and resolution. Regulatory organizations have strict compliance requirements and an unprecedented ability to levy fines. Reporting requirements have increased, all in an environment of tight budgets and limited personnel. The media also is eager to sensationalize security incidents or weaknesses in public and natural resources. Traditional SCADA systems, with their expensive architecture and manpower intensity, fall short of current needs. A fresh contemporary approach is needed.

In many distributed utilities, the applications are small, the site is remote, and the costs for both the SCADA software and the communications infrastructure are high. But imagine if there were a robust remote controller with built in SCADA able to utilize existing public network infrastructure that was easy to configure and install. This would also include advanced security detection and alarm reporting providing information when and where you need it. Sound too good to be true, it is available today.

This paper outlines a new approach, "Distributed SCADA" that matches contemporary needs and requirements using open and proven IP technology while completely eliminating many of the existing concerns and costs associated with small- to medium-sized municipal and utility applications. At the conclusion of this document a case study is provided comparing a traditional wastewater system to a new Distributed SCADA solution approach.

The New Architecture

Despite the broad choice of solutions for remotely controlled equipment and centralized monitoring systems, it is no longer necessary to use traditional and discrete devices such as a PLC, modem/dialer, data logger or SCADA PC and then experience the agonies of integration. Imagine a new industrial solution whose simplicity rivals your cell phone/PDA — with all of the features included in one device and with one easy-to-use interface. This is the new, cost-effective all-in-one, intelligent Telecontroller.

The Integrated Hybrid Telecontroller

Using a traditionally deployed programmable logic controller (PLC), RTU, and SCADA system require the complex integration of many different devices. Frequently, these devices are from different vendors and have varying form factors. Each is programmed and configured with its own software and has limited levels of interoperability. A combination of communication ports, drivers, protocols and database interfaces are needed for all the components to work together. An experienced integration contractor, comprehensive system specifications, and strong adherence to the requirements are essential with this type of solution.

In contrast, new technology on the market today offers complete, out-of-the box solutions for remote applications. Semaphore's T-BOX line is a good example of this innovative new Telecontroller technology. Its benefits include a single, streamlined software package, plug-and-play functionality for all system components, consistency in the hardware form factor, interoperability, and vastly reduced integration and wiring requirements. Embedded HMI and SCADA solutions are even provided allowing access to the process from a standard web browser at any location without the need for costly or proprietary SCADA software installed on a dedicated PC.

Intelligent Pre-Processing and Intelligent Alarming

With the lower cost of memory devices and more powerful microcontrollers, it has now become practical to distribute the processing and data logging operations at the remote outstations. Events can be interpreted and acted on at a local level without interaction or “polling” from the master control. Data logging and trend analysis can also be provided locally eliminating the need for large amounts of remote data transfer. Events and data can be stored at both the local and remote station to add a second level of data integrity. Since there is pre-processing, intelligent alarming by the remote Telecontroller is now possible. Standardized alarm routing, masking, acknowledgement, and escalation are simple to implement.

Streamlined, Low-Cost Reporting Capabilities

The new technology also allows for the consolidation/aggregation of data long term from multiple stations without the expense of historian software or polling from a master control station. For example, Semaphore’s T-VIEW and DreamReport™ software module can collect data from multiple T-BOX stations via email or FTP. The software provides easily customizable reports with graphical views and provides analytical information in PDF or Excel reports, which are automatically generated and distributed to printers, email, FTP or accessible via a Web portal. DreamReport can be used to analyze, generate, and distribute this data. T-VIEW plays a similar role for visualization and can serve as a historian. In addition, it provides “on-the-fly” export of historical data to database programs such as Oracle, ODBC, and SQL.

Push vs. Pull

Today, data, statistics, and alarms can be transferred per event instead of relying on a traditional polling communications scheme. This means that even a traditional dial-up phone line can now be used effectively for remote sites. In the past the limitation of the hardware, proprietary protocols, and dedicated line interconnections made it costly and difficult to use a push communications strategy. The SCADA system was centrally located and needed to continually “poll” each outstation to collect relevant data. Today, embedded data logging and SCADA functions allow multiple remote stations to send information directly when and where required in an asynchronous manner without any concern for collisions or open connections at the master controller and SCADA. With a large number of outstations, the push model better utilizes the available bandwidth.

Leveraging Internet technology

IP technologies, including the internet, have become cost effective for remote monitoring and control when compared to dedicated radio telemetry and leased phone lines. IP topologies are now used to access many outstations effectively and securely. Remote stations can dynamically and simultaneously send data via email, SMS, text messaging and FTP. This data can be consumed and displayed by a centralized SCADA system and reporting software, or sent directly to individual users.

A few advanced Telecontrol products, such as Semaphore’s T-BOX system, offer embedded WEB SCADA and HMI at the remote stations. This allows both local and remote users to access the individual outstations directly without any special software or a PC to host the services. IP security cameras and access devices are easily integrated into a seamless solution at the outstation with the standardization of Internet technology. A wide array of communications may be used to connect to the remote stations, such as PSTN modem, radio, broadband, DSL, and cellular GSM + GPRS.

Integration

A major consideration in developing and maintaining a Telecontrol solution is the ease and level of integrating the devices and functions required. Communications interfaces can be the most complex to integrate, especially when there are varied protocols, different vendors, and an array of cabling interfaces. All too common is the finger pointing that occurs when multiple vendors and integrators shift accountability to each other when system components fail to communicate. Integrated Telecontrol RTU products, such as Semaphore's T-BOX systems, eliminate the majority of these issues.

Case Study

A water utility client is installing a new wastewater lift station and requested a quotation to control and monitor the dual wet-well pumping station. The remote site will not be manned and will only be physically checked once a week or when a critical condition occurs.

The engineering firm hired by the utility has specified the use of traditional and discrete devices and a SCADA system to be integrated into the outstation based on a previous project 5 years earlier. The utility has a \$30,000 budget for the SCADA solution's electrical equipment, installation, and integration.

A traditional SCADA and RTU solution was quoted based on the specified components. A summary of the costs are as follows:

- Outstation, including PLC, modem-dialer, datalogger, PC, SCADA software and UPS: \$14,330
- Master SCADA including PC, SCADA, alarming and remote access software and UPS: \$6,180
- Engineering, integration, panel enclosures, piping and wire, system installation, and start-up: \$25,000

Sub-Total \$45,560 **Over Budget** \$15,560

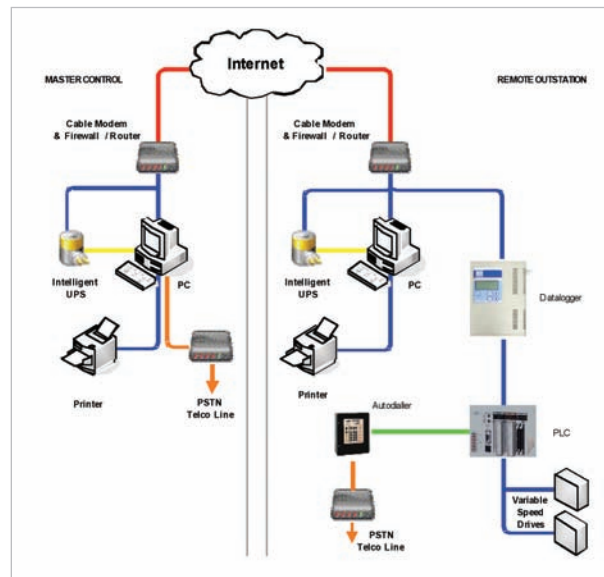

Figure 1: Traditional SCADA and RTU System Architecture

An alternative bid was also submitted using a new multi-function Telecontrol and SCADA-based solution using the following components.

The outstation includes:

- A modular de-centralized Telecontrol product with power supply, processor, communications and IO modules, HMI, and configuration software: \$6,730
- Master SCADA including PC, Web browser software and UPS: \$3,600
- Engineering, integration, panel enclosures, piping and wire, system installation, and start-up: \$18,000

Sub-Total \$28,330 **Under Budget** \$ 1,670

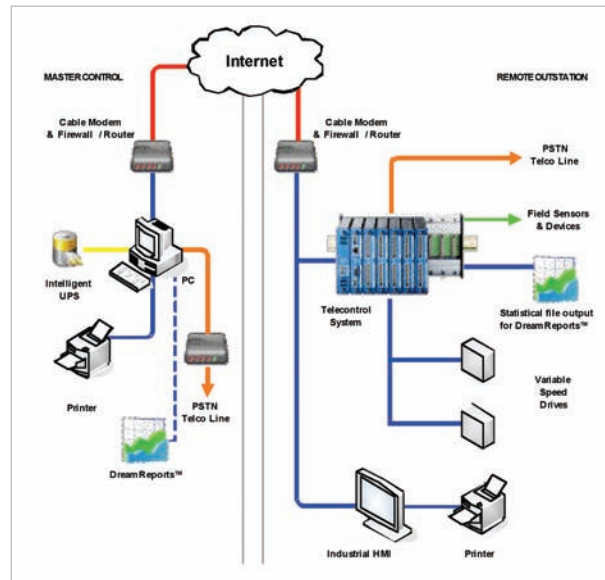

Figure 2: New Multi-function Telecontrol System Architecture

Conclusion

A traditional implementation of an RTU, PLC, and SCADA system can be a complex and overwhelming task to integrate and maintain when considering the specification, integration, engineering, and hardware costs.

With the advent of multi-function Telecontrol products specifically designed for remote applications, many advantages and benefits may be achieved versus traditional solutions:

- Purchased equipment cost reduced 30% to 50%
- 30% or more reduction in programming and integration efforts across the system
- Single software interface to develop and maintain system via one common connection to access all system functions
- Common form factor and plug-and-play operation of system devices and functions
- Pre-designed and tested solutions for peripheral functions
- No dependency on central SCADA system
- Powerful, scalable, and open solutions offering common interfaces to existing and new installations — i.e. IP communications, Modbus, DNP3

About the Author

James M. DiNanno is a sales and marketing executive for Hollis Technologies. With more than 20 years as a control systems design engineer and product marketing manager, his experience has ranged from process equipment to robotic work cells and machine vision systems.

About Hollis Technologies

Hollis Technologies is a distributor and manufacturer's representative for leading hardware and software products for industrial and infrastructure applications, including T-BOX from CSE-Semaphore (www.cse-semaphore.com), a leading Telecontrol product featuring Distributed SCADA capabilities and DreamReports.

Hollis Technologies

15B Charron Avenue
Nashua, New Hampshire 03063

Tel: 603-577-8958

Fax: 603-880-4827

Web: www.hollis-tech.com

e-mail: jdinanno@hollis-tech.com

www.cse-semaphore.com

U.S.A.

CSE Semaphore Inc.
1200 Chantry Place
Lake Mary, FL 32746
U.S.A.

P +1 (407) 333 3235
F +1 (407) 386 6284

Australia

CSE-Semaphore
Unit 8, 3-5 Gilda Crt
Mulgrave, Victoria 3170
Australia

P +61 (03) 8544 8544
F +61 (03) 8544 8555

Europe

CSE-Semaphore Belgium
Waterloo Office Park — Building "M"
Dreve Richelle, 161
B-1410 Waterloo
Belgium

P +32 (2) 387 42 59
F +32 (2) 387 42 75

© 2007 CSE-Semaphore. All rights reserved. T-BOX, T-VIEW, and Dream Report are trademarks of CSE-Semaphore. All other marks may be trademarks of their respective owners. 0761012 10/07

About Semaphore

Semaphore offers the first IP-based RTU solutions that enable complete integration of SCADA, control, and communications functionality in one rugged package. Our simple yet powerful products leverage easy-to-use Web technologies and inexpensive public networks. They are easy to configure and offer dramatically reduced costs versus traditional SCADA/PLC systems.

Semaphore is a part of CSE-Global, a leading systems integrator with an international presence spanning the Americas, Asia Pacific, Europe, Africa, and the Middle East. The group employs over 1,200 people worldwide, with more than 85% representing design, engineering, and project management capabilities and experience. That makes CSE one of the largest independent system providers of its kind.